

DDR5 SDRAM-SODIMM

8GB based on 16Gbit (2Gx4) component



Revision 1.0 (APR., 2026)
-Initial Release

1. Features

- DDR5 functionality and operations supported as defined in the component data sheet
- Features and specifications defined in the DDR5 SODIMM core data sheet
- 262-pin, DDR5 unbuffered dual in-line memory module (DDR5 SODIMM)
- Fast data transfer rate: PC5-5600
- 8GB (1Gig x 64)
- Single-rank
- 16 internal banks; 4 groups of 4 banks each

2. Ordering Information

Part Number	Density	Organization	Component Composition	# of Rank	Description
FD556S8GV	8GB	1Gx64	1Gx16 x 4pcs	1	PC5-5600

Note: Last character of the Part Number (x) represents DRAM vendor
S=Samsung; M=Micron; H=Hynix

3. Key Timing Parameters

	DDR5-5600	Unit
CL-tRCD-tRP	46-45-45	tCK
CAS Latency	46	tCK

4. Address Configuration

Organization	Row Address	Column Address	Bank Address	Bank Group Address	Module rank address
1Gx16(16Gb) base	A0-A15	A0-A9	BA0-BA1	BG0-BG1	CS0_n

5. DIMM Pin Descriptions

Pin Name	Description	Pin Name	Description
CA0_A – CA12_A, CA0_B – CA12_B	SDRAM Command/Address bus	HSCL	SidebandBus clock
CS0_A_n – CS1_A_n, CS0_B_n – CS1_B_n	SDRAM Chip Select	HSDA	SidebandBus data
DQ0_A – DQ31_A, DQ0_B – DQ31_B	DIMM memory data bus	HSA	SidebandBus address
CB0_A – CB3_A, CB0_B – CB3_B	DIMM ECC check bits	ALERT_n	SDRAM ALERT_n
DQS0_A_t – DQS4_A_t, DQS0_B_t – DQS4_B_t	SDRAM data strobes (positive line of differential pair)	RESET n	Set DRAMs to a Known State
DQS0_A_c – DQS4_A_c, DQS0_B_c – DQS4_B_c	SDRAM data strobes (negative line of differential pair)	VIN_BULK	5 V power input supply to the PMIC for analog circuits
DM0_A_n – DM3_A_n, DM0_B_n – DM3_B_n	SDRAM data masks	VSS	Power supply return (ground)
CK0_A_t, CK1_A_t, CK0_B_t, CK1_B_t	SDRAM clocks (positive line of differential pair)	PWR_GOOD	Power good indicator
CK0_A_c, CK1_A_c, CK0_B_c, CK1_B_c	SDRAM clocks (negative line of differential pair)	PWR_EN	PMIC Enable
		RFU	Reserved for future use

NOTE 1 : DDR5 SODIMM has 2 channels (channel-A and channel-B) of signal bus. The signals with suffix: _A (e.g., DQ0_A) are for channel-A, and the signals with suffix: _B (e.g., DQ0_B) are for channel-B

6. Input/Output Functional Descriptions

Symbol	Type	Function
CK0_A_t, CK0_A_c CK1_A_t, CK1_A_c, CK0_B_t, CK0_B_c CK1_B_t, CK1_B_c	Input	Clock: CK_t and CK_c are differential clock inputs. All address and control input signals are sampled on the crossing of the positive edge of CK_t and negative edge of CK_c.
CA0_A – CA12_A, CA0_B – CA12_B	Input	Command/Address Inputs: CA signals provide the command and address inputs according to the Command Truth Table. Note: Since some commands are multi cycle, the pins may not be interchanged between devices on the same bus.
CS0_A_n – CS1_A_n CS0_B_n – CS1_B_n	Input	Chip Select: All commands are masked when CS_n is registered HIGH. CS_n provides for external Rank selection on systems with multiple Ranks. CS_n is considered part of the command code. CS_n is also used to enter and exit the parts from power down modes.
DQ0_A – DQ31_A DQ0_B – DQ31_B	Input / Output	Data Input/Output: Bi-directional data bus. If CRC is enabled via Mode Register, then CRC code is added at the end of Data Burst.

Symbol	Type	Function
CB0_A – CB3_A CB0_B – CB3_B	Input / Output	DIMM ECC check bits
DQS0_A_t – DQS4_A_t DQS0_A_c – DQS4_A_c DQS0_B_t – DQS4_B_t DQS0_B_c – DQS4_B_c	Input / Output	Data Strobe: output with read data, input with write data. Edge-aligned with read data, centered in write data. DDR5 SDRAM supports differential data strobe only and does not support single-ended.
DM0_A_n – DM3_A_n DM0_B_n – DM3_B_n	Input	Input Data Mask: DM_n is an input mask signal for write data. Input data is masked when DM_n is sampled LOW coincident with that input data during a Write access. DM_n is sampled on both edges of DQS. For x8 device, the function of DM_n is enabled by MR5:OP[5]=1.
ALERT_n	Input / Output	Alert: If there is error in CRC, then Alert_n goes LOW for the period time interval and goes back HIGH. During Connectivity Test mode, this pin works as input. Using this signal or not is dependent on system. In case of not connected as Signal, ALERT_n Pin must be bounded to VDDQ on board.
RESET_n	Input	Active Low Asynchronous Reset: Reset is active when RESET_n is LOW, and inactive when RESET_n is HIGH. RESET_n must be HIGH during normal operation. RESET_n is a CMOS rail to rail signal with DC high and low at 80% and 20% of VDDQ,
HSCL	Input	Host SidebandBus bus clock, supplied by the controller.
HSDA	Input / Output	Host SidebandBus data, connected from the controller to Hub or Host bus Target devices.
HSA	Input	Host SidebandBus bus device ID address pin; input to a Hub or other client device to distinguish between identical devices in the I3C-Basic address range.
RFU		
PWR_GOOD	Open Drain	Power good indicator. Open Drain output. The PMIC floats this pin high when VIN_Bulk input supply as well as all enabled output buck regulators and all LDO regulator tolerance threshold is maintained as configured in appropriate register. The PMIC drives this pin low when VIN_Bulk input goes below the threshold or when any of the enabled switch output regulators exceed the threshold configured in the appropriate register or any LDO output regulator exceeds the threshold tolerance. Input: The PMIC disables its output regulators when this pin is low. The LDO outputs shall remain on.
PWR_EN	Input	PMIC Enable. When this pin is high, the PMIC turns on the regulator. When this pin is low, the PMIC turns off the regulator. This signal is connected to PMIC's VR_EN pin.
VIN_BULK	Supply	5 V power input supply to the PMIC for analog circuits.
VSS	Supply	Ground

262-pin SODIMM

DDR5 SDRAM

7. Pin Assignmen

Pin#	Front Side	Pin#	Back Side	Pin#	Front Side	Pin#	Back Side
1	VIN_BULK	2	HSA	131	CK0_A_t	132	CK1_A_t
3	VIN_BULK	4	HSCL	133	CK0_A_c	134	CK1_A_c
5	RFU	6	HSDA	135	VSS	136	VSS
7	PWR_GOOD	8	PWR_EN	137	CK0_B_t	138	CK1_B_t
9	VSS	10	VSS	139	CK0_B_c	140	CK1_B_c
11	DQ0_A	12	DQ1_A	141	VSS	142	VSS
13	VSS	14	VSS	143	RFU	144	CA12_B
15	DQ2_A	16	DQ3_A	145	CA11_B	146	CA10_B
17	VSS	18	VSS	147	VSS	148	VSS
19	DM0_A_n	20	DQS0_A_c	149	CA9_B	150	CA8_B
21	VSS	22	DQS0_A_t	151	CA7_B	152	CA6_B
23	DQ4_A	24	VSS	153	VSS	154	VSS
25	VSS	26	DQ5_A	155	CA5_B	156	CA4_B
27	DQ6_A	28	VSS	157	CA3_B	158	CA2_B
29	VSS	30	DQ7_A	159	VSS	160	VSS
31	DQ8_A	32	VSS	161	CS0_B_n	162	CA1_B
33	VSS	34	DQ09_A	163	RESET_n	164	CA0_B
35	DQ10_A	36	VSS	165	CS1_B_n	166	VSS
37	VSS	38	DQ11_A	167	VSS	168	CB0_B
39	DQS1_A_c	40	VSS	169	DQS4_B_c	170	VSS
41	DQS1_A_t	42	DM1_A_n	171	DQS4_B_t	172	CB1_B
43	VSS	44	VSS	173	VSS	174	VSS
45	DQ12_A	46	DQ13_A	175	CB3_B	176	CB2_B
47	VSS	48	VSS	177	VSS	178	VSS
49	DQ14_A	50	DQ15_A	179	DQ0_B	180	DQ1_B
51	VSS	52	VSS	181	VSS	182	VSS
53	DQ16_A	54	DQ17_A	183	DQ2_B	184	DQ3_B
55	VSS	56	VSS	185	VSS	186	VSS
57	DQ18_A	58	DQ19_A	187	DM0_B_n	188	DQS0_B_c
59	VSS	60	VSS	189	VSS	190	DQS0_B_t
61	DM2_A_n	62	DQS2_A_c	191	DQ4_B	192	VSS
63	VSS	64	DQS2_A_t	193	VSS	194	DQ5_B
65	DQ20_A	66	VSS	195	DQ6_B	196	VSS
67	VSS	68	DQ21_A	197	VSS	198	DQ7_B
69	DQ22_A	70	VSS	199	DQ8_B	200	VSS

262-pin SODIMM

DDR5 SDRAM

71	VSS	72	DQ23_A	201	VSS	202	DQ9_B
73	DQ24_A	74	VSS	203	DQ10_B	204	VSS
75	VSS	76	DQ25_A	205	VSS	206	DQ11_B
77	DQ26_A	78	VSS	207	DQS1_B_c	208	VSS
79	VSS	80	DQ27_A	209	DQS1_B_t	210	DM1_B_n
81	DQS3_A_c	82	VSS	211	VSS	212	VSS
83	DQS3_A_t	84	DM3_A_n	213	DQ12_B	214	DQ13_B
85	VSS	86	VSS	215	VSS	216	VSS
87	DQ28_A	88	DQ29_A	217	DQ14_B	218	DQ15_B
89	VSS	90	VSS	219	VSS	220	VSS
91	DQ30_A	92	DQ31_A	221	DQ16_B	222	DQ17_B
93	VSS	94	VSS	223	VSS	224	VSS
95	CB0_A	96	CB1_A	225	DQ18_B	226	DQ19_B
97	VSS	98	VSS	227	VSS	228	VSS
99	CB2_A	100	DQS4_A_c	229	DM2_B_n	230	DQS2_B_c
101	VSS	102	DQS4_A_t	231	VSS	232	DQS2_B_t
103	CB3_A	104	VSS	233	DQ20_B	234	VSS
105	VSS	106	CS0_A_n	235	VSS	236	DQ21_B
107	CA0_A	108	ALERT_n	237	DQ22_B	238	VSS
109	CA1_A	110	CS1_A_n	239	VSS	240	DQ23_B
111	VSS	112	VSS	241	DQ24_B	242	VSS
113	CA2_A	114	CA3_A	243	VSS	244	DQ25_B
115	CA4_A	116	CA5_A	245	DQ26_B	246	VSS
117	VSS	118	VSS	247	VSS	248	DQ27_B
119	CA6_A	120	CA7_A	249	DQS3_B_c	250	VSS
121	CA8_A	122	CA9_A	251	DQS3_B_t	252	DM3_B_n
123	VSS	124	VSS	253	VSS	254	VSS
125	CA10_A	126	CA11_A	255	DQ28_B	256	DQ29_B
KEY				257	VSS	258	VSS
127	CA12_A	128	RFU	259	DQ30_B	260	DQ31_B
129	VSS	130	VSS	261	VSS	262	VSS

8. Absolute Maximum DC Ratings

Symbol	Parameter	Rating	Units	NOTE
VDD	Voltage on VDD pin relative to Vss	-0.3 ~ 1.4	V	1,3
VDDQ	Voltage on VDDQ pin relative to Vss	-0.3 ~ 1.4	V	1,3
VPP	Voltage on VPP pin relative to Vss	-0.3 ~ 2.1	V	4
V _{IN} , V _{OUT}	Voltage on any pin relative to Vss	-0.3 ~ 1.4	V	1,3,5
T _{STG}	Storage Temperature	-55 to +100	°C	1,2

NOTE 1 Stresses greater than those listed under “Absolute Maximum Ratings” may cause permanent damage to the device. This is a stress rating only and functional operation of the device at these or any other conditions exceeding those indicated in the operational sections of this specification is not implied. Exposure to absolute maximum rating conditions for extended periods may affect reliability

NOTE 2 Storage Temperature is the case surface temperature on the center/top side of the DRAM. For the measurement conditions, please refer to JESD51-2 standard.

NOTE 3 VDD and VDDQ must be within 300 mV of each other at all times. When VDD and VDDQ are less than 500 mV

NOTE 4 VPP must be equal or greater than VDD/VDDQ at all times.

NOTE 5 Overshoot area above 1.5 V is specified in Section 8.3.4, Section 8.3.5, and Section 8.3.6.

9. DRAM Component Operating Temperature Range

Symbol	Parameter	Rating	Units	NOTE
T _{OPER}	Normal Operating Temperature Range	0 to 85	°C	1,2,3
	Extended Temperature Range	85 to 95	°C	1,2,3,4

NOTE 1 Operating Temperature is the case surface temperature on the center/top side of the DRAM. For the measurement conditions, please refer to JESD51-2 standard.

NOTE 2 The Normal Temperature Range specifies the temperatures where all DRAM specifications will be supported. During operation, the DRAM case temperature must be maintained between 0 to 85°C under all operating conditions.

NOTE 3 Operating Temperature for 3DS needs to be derated by the number of DRAM dies as: $[T_{OPER} - (2.5^{\circ}\text{C} \times \log_2 N)]$, where N is the number of the stacked dies.

NOTE 4 Some applications require operation of the DRAM in the Extended Temperature Range between 85°C and 95°C case temperature. Full specifications are supported in this range, but the following additional conditions apply:

- Refresh commands must be doubled in frequency, therefore reducing the Refresh interval tREFI to 3.9us. It is also possible to specify a component with 1X refresh (tREFI to 7.8us) in the Extended Temperature Range. Please refer to supplier's datasheet and/or the DIMM SPD for option availability.
- If Self-Refresh operation is required in the Extended Temperature Range, then it is mandatory to either use the Manual Self-Refresh mode with Extended Temperature Range capability (MR2 A6=0b and MR2 A7=1b) or enable the optional Auto Self-Refresh mode (MR2 A6=1b and MR2 A7=0b). Please refer to the supplier's datasheet and/or the DIMM SPD for Auto Self-Refresh option availability. Extended Temperature Range support and tREFI requirements in the Extended Temperature Range.

10. Functional Block Diagram:

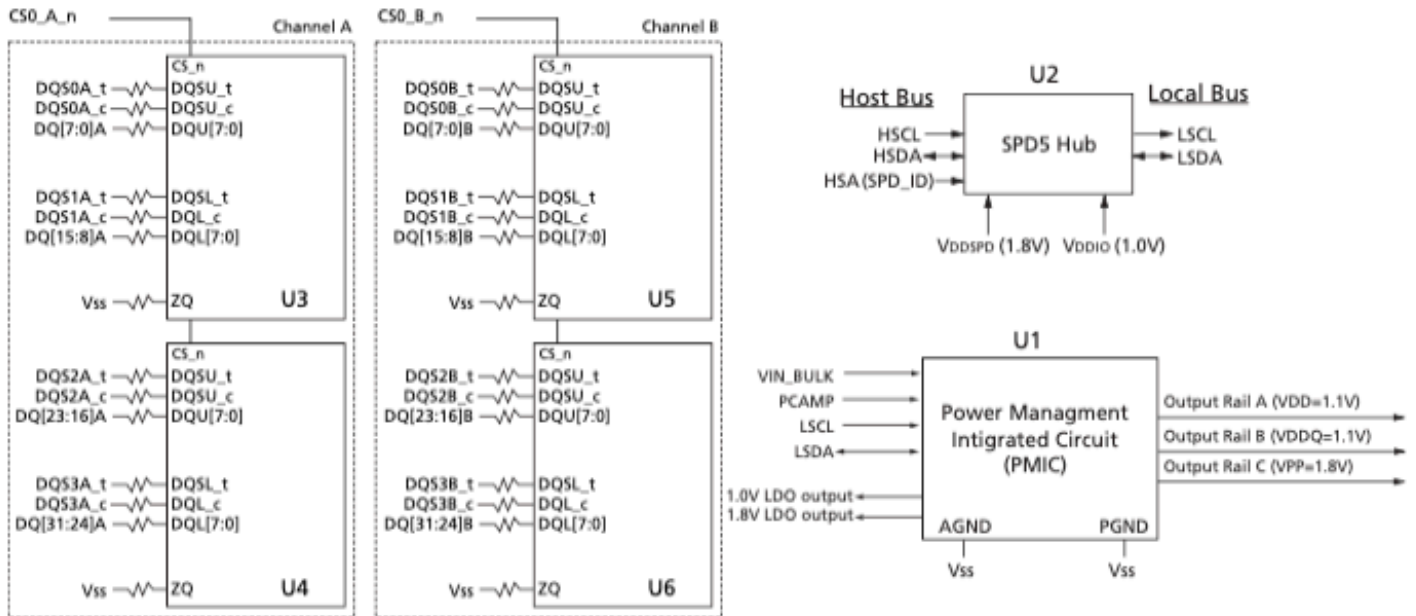

- Notes: 1. The ZQ ball on each DDR5 component is connected to an external 240Ω ±1% resistor that is tied to ground. It is used for the calibration of the component's ODT and output driver.
2. Functional block diagram is for reference only.

11. AC&DC Operating Conditions

Recommended operating conditions (Voltage referred to $V_{SS}=0V$, $T_A=0$ to $70^{\circ}C$)

Symbol	Parameter	Min	Typ	Max	Unit
V_{DD}	Device Supply Voltage	1.067	1.1	1.166	V
V_{DDQ}	Supply Voltage for I/O	1.067	1.1	1.166	V
V_{PP}	Core Power Voltage	1.746	1.8	1.908	V

12. Physical Dimensions:

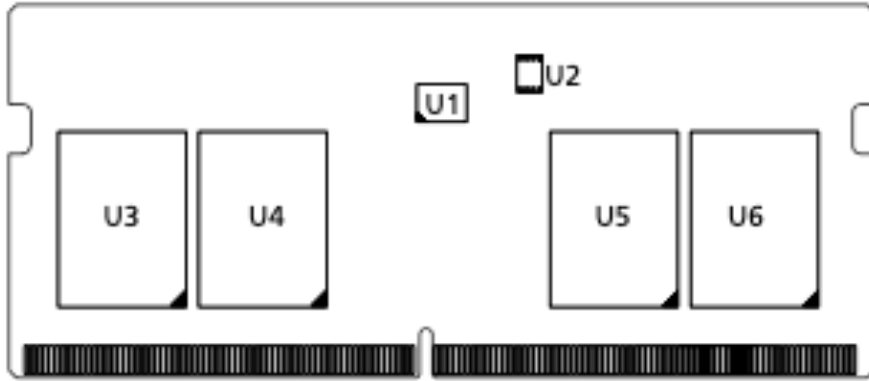

Primary side

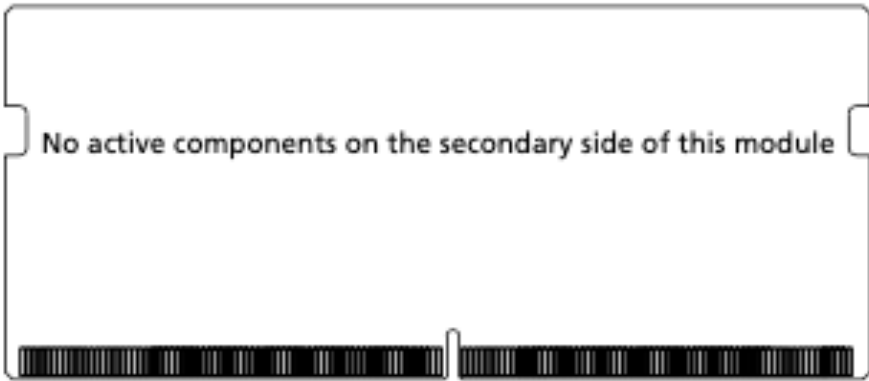

Secondary Side