

DDR3 Registered/ECC DIMM Module

1GB, 2GB, 4GB based on 1Gbit component

60FBGA with Pb-Free



Revision 1.0 (May, 2008)
-Initial Release

1.0 Feature

- JEDEC standard $V_{DDQ}=1.5V \pm 0.075V$ Power Supply
- 1.5V centered-terminated push-pull I/O
- Programmable CAS latencies (5,6,7,8,9,10), Burst Length (4 & 8) and Burst Type
- Auto Refresh (CRB) and Self Refresh
- Bi-directional Differential Data Strobe
- Off Chip Driver (OCD) impedance adjustment
- On-Die termination using ODT pin
- 8 independent internal bank
- Average Refresh Period 7.8us at lower than a TCASE 85°C, 3.9us at 85°C < TCASE < 95 °C - support High Temperature Self-Refresh rate enable feature
- Serial presence detect with EEPROM
- RDIMM Dimension (Nominal) 30.00 mm high, 133.35 mm wide
- Based on JEDEC standard reference Raw Cards Lay out.
- RoHS compliant
- Gold plated contacts

2.0 Ordering Information

| Part number | Density | Module Organization | Component composition | Component PKG | Module Rank | Description |
|-------------|---------|---------------------|-----------------------|---------------|-------------|-------------|
| W10RA1G8X | 1GB | 128Mx72 | 128Mx8*9 | FBGA | 1 | PC3-8500 |
| W13RA1G8X | 1GB | 128Mx72 | 128Mx8*9 | FBGA | 1 | PC3-10600 |
| W10RB2G8X | 2GB | 256Mx72 | 128Mx8*18 | FBGA | 2 | PC3-8500 |
| W13RB2G8X | 2GB | 256Mx72 | 128Mx8*18 | FBGA | 2 | PC3-10600 |
| W10RA2G4X | 2GB | 256Mx72 | 256Mx4*18 | FBGA | 1 | PC3-8500 |
| W13RA2G4X | 2GB | 256Mx72 | 256Mx4*18 | FBGA | 1 | PC3-10600 |
| W10RB4G4X | 4GB | 512Mx72 | 256Mx4*36 | FBGA | 2 | PC3-8500 |
| W13RB4G4X | 4GB | 512Mx72 | 256Mx4*36 | FBGA | 2 | PC3-10600 |

Note: Last Character x of the Part Number stands for DRAM vendor
S=Samsung; M=Micron; Q=Qimonda; H=Hynix; E=Elpida

3.0 Operating Frequencies

| | DDR3-1333 | DD3-1066 | Unit |
|-------------|------------------|-----------------|-------------|
| CL-tRCD-tRP | 9-9-9 | 7-7-7 | tCK |
| CAS Latency | 9 | 7 | tCK |
| tCK(min) | 1.5 | 1.875 | ns |
| tRCD(min) | 13.5 | 13.125 | ns |
| tRP(min) | 13.5 | 13.125 | ns |
| tRAS(min) | 36 | 37.5 | ns |
| tRC(min) | 49.5 | 50.625 | ns |

4.0 Absolute Maximum DC Rating

| Symbol | Parameter | Rating | Units |
|-------------------|---|---------------|--------------|
| V_{in}, V_{out} | Voltage on any pin relative to V_{SS} | -0.4 ~ 1.975 | V |
| V_{DD} | Voltage on V_{DD} & V_{DDQ} supply relative to V_{SS} | -0.4 ~ 1.975 | V |
| V_{DDQ} | Short circuit current | -0.4 ~ 1.975 | V |
| V_{DDL} | Power dissipation | -0.4 ~ 1.975 | V |
| T_{STG} | Storage Temperature | -55 ~ + 100 | °C |

5.0 DIMM Pin Configurations (Front side/Back side)

| Pin | Front | Pin | Back | Pin | Front | Pin | Back | Pin | Front | Pin | Back | Pin | Front | Pin | Back |
|-----|--------------------------|-----|---------------------------|-----|--|-----|---------------------------|-----|--------------------------|-----|---------------------------|------|--------------------------|-----|---------------------------|
| 1 | V _{REFDQ} | 121 | V _{SS} | 31 | DQ25 | 151 | V _{SS} | 61 | A2 | 181 | A1 | 91 | DQ41 | 211 | V _{SS} |
| 2 | V _{SS} | 122 | DQ4 | 32 | V _{SS} | 152 | DQS12 | 62 | V _{DD} | 182 | V _{DD} | 92 | V _{SS} | 212 | DQS14 |
| 3 | DQ0 | 123 | DQ5 | 33 | $\overline{\text{DQS3}}$ | 153 | $\overline{\text{DQS12}}$ | 63 | NC | 183 | V _{DD} | 93 | $\overline{\text{DQS5}}$ | 213 | $\overline{\text{DQS14}}$ |
| 4 | DQ1 | 124 | V _{SS} | 34 | DQS3 | 154 | V _{SS} | 64 | NC | 184 | CK0 | 94 | DQS5 | 214 | V _{SS} |
| 5 | V _{SS} | 125 | DQS9 | 35 | V _{SS} | 155 | DQ30 | KEY | | | | 95 | V _{SS} | 215 | DQ46 |
| 6 | $\overline{\text{DQS0}}$ | 126 | $\overline{\text{DQS9}}$ | 36 | DQ26 | 156 | DQ31 | 65 | V _{DD} | 185 | $\overline{\text{CK0}}$ | DQ47 | DQ42 | 216 | DQ47 |
| 7 | DQS0 | 127 | V _{SS} | 37 | DQ27 | 157 | V _{SS} | 66 | V _{DD} | 186 | V _{DD} | 97 | DQ43 | 217 | V _{SS} |
| 8 | V _{SS} | 128 | DQ6 | 38 | V _{SS} | 158 | CB4 | 67 | V _{REFCA} | 187 | $\overline{\text{EVENT}}$ | 98 | V _{SS} | 218 | DQ52 |
| 9 | DQ2 | 129 | DQ7 | 39 | CB0 | 159 | CB5 | 68 | NC/Par_in | 188 | A0 | 99 | DQ48 | 219 | DQ53 |
| 10 | DQ3 | 130 | V _{SS} | 40 | CB1 | 160 | V _{SS} | 69 | V _{DD} | 189 | V _{DD} | 100 | DQ49 | 220 | V _{SS} |
| 11 | V _{SS} | 131 | DQ12 | 41 | V _{SS} | 161 | DQS17 | 70 | A10/AP | 190 | BA1 | 101 | V _{SS} | 221 | DQS15 |
| 12 | DQ8 | 132 | DQ13 | 42 | $\overline{\text{DQS8}}$ | 162 | $\overline{\text{DQS17}}$ | 71 | BA0 | 191 | V _{DD} | 102 | $\overline{\text{DQS6}}$ | 222 | $\overline{\text{DQS15}}$ |
| 13 | DQ9 | 133 | V _{SS} | 43 | DQS8 | 163 | V _{SS} | 72 | V _{DD} | 192 | $\overline{\text{RAS}}$ | 103 | DQS6 | 223 | V _{SS} |
| 14 | V _{SS} | 134 | DQS10 | 44 | V _{SS} | 164 | CB6 | 73 | $\overline{\text{WE}}$ | 193 | $\overline{\text{S0}}$ | 104 | V _{SS} | 224 | DQ54 |
| 15 | $\overline{\text{DQS1}}$ | 135 | $\overline{\text{DQS10}}$ | 45 | CB2 | 165 | CB7 | 74 | $\overline{\text{CAS}}$ | 194 | V _{DD} | 105 | DQ50 | 225 | DQ55 |
| 16 | DQS1 | 136 | V _{SS} | 46 | CB3 | 166 | V _{SS} | 75 | V _{DD} | 195 | ODT0 | 106 | DQ51 | 226 | V _{SS} |
| 17 | V _{SS} | 137 | DQ14 | 47 | V _{SS} | 167 | NC | 76 | NC | 196 | A13 | 107 | V _{SS} | 227 | DQ60 |
| 18 | DQ10 | 138 | DQ15 | 48 | V _{TT} | 168 | $\overline{\text{RESET}}$ | 77 | NC | 197 | V _{DD} | 108 | DQ56 | 228 | DQ61 |
| 19 | DQ11 | 139 | V _{SS} | 49 | V _{TT} | 169 | NC | 78 | V _{DD} | 198 | NC | 109 | DQ57 | 229 | V _{SS} |
| 20 | V _{SS} | 140 | DQ20 | 50 | CKE0 | 170 | V _{DD} | 79 | NC | 199 | V _{SS} | 110 | V _{SS} | 230 | DQS16 |
| 21 | DQ16 | 141 | DQ21 | 51 | V _{DD} | 171 | A15 | 80 | V _{SS} | 200 | DQ36 | 111 | $\overline{\text{DQS7}}$ | 231 | $\overline{\text{DQS16}}$ |
| 22 | DQ17 | 142 | V _{SS} | 52 | BA2 | 172 | A14 | 81 | DQ32 | 201 | DQ37 | 112 | DQS7 | 232 | V _{SS} |
| 23 | V _{SS} | 143 | DQS11 | 53 | $\overline{\text{E}}_{\text{RR_OUT}}$ | 173 | V _{DD} | 82 | DQ33 | 202 | V _{SS} | 113 | V _{SS} | 233 | DQ62 |
| 24 | $\overline{\text{DQS2}}$ | 144 | $\overline{\text{DQS11}}$ | 54 | V _{DD} | 174 | A12 | 83 | V _{SS} | 203 | $\overline{\text{DQS13}}$ | 114 | DQ58 | 234 | DQ63 |
| 25 | DQS2 | 145 | V _{SS} | 55 | A11 | 175 | A9 | 84 | $\overline{\text{DQS4}}$ | 204 | DQS13 | 115 | DQ59 | 235 | V _{SS} |
| 26 | V _{SS} | 146 | DQ22 | 56 | A7 | 176 | V _{DD} | 85 | DQS4 | 205 | V _{SS} | 116 | V _{SS} | 236 | V _{DD} SPD |
| 27 | DQ18 | 147 | DQ23 | 57 | V _{DD} | 177 | A8 | 86 | V _{SS} | 206 | DQ38 | 117 | SA0 | 237 | SA1 |
| 28 | DQ19 | 148 | V _{SS} | 58 | A5 | 178 | A6 | 87 | DQ34 | 207 | DQ39 | 118 | SCL | 238 | SDA |
| 29 | V _{SS} | 149 | DQ28 | 59 | A4 | 179 | V _{DD} | 88 | DQ35 | 208 | V _{SS} | 119 | SA2 | 239 | V _{SS} |
| 30 | DQ24 | 150 | DQ29 | 60 | V _{DD} | 180 | A3 | 89 | V _{SS} | 209 | DQ44 | 120 | V _{TT} | 240 | V _{TT} |
| | | | | | | | | 90 | DQ40 | 210 | DQ45 | | | | |

6.0 DIMM Pin Description

| Pin Name | Function | Pin Name | Function |
|---|---|--|-------------------------------------|
| A0 ~ A15 | Address input (Multiplexed) | ODT0~ODT1 | On Die Termination |
| A10/AP | Address Input/Auto pre-charge | CB0~CB7 | ECC Data check bits Input/Output |
| BA0 ~ BA2 | Bank Select | DQ0~DQ63 | Data Input/Output |
| $\overline{CK0} \sim \overline{CK2}$, CK0~CK2 | Clock input | $\overline{DQS0} \sim \overline{DQS8}$ | Data strobes, negative line |
| CKE0, CKE1 | Clock enable input | DM (0~8), | Data Masks/Data strobes (Read) |
| $\overline{S0}$, $\overline{S1}$ | Chip select input | DQS0~DQS8 | Data Strobes |
| \overline{RAS} | Row address strobe | RFU | Reserved for future used |
| \overline{CAS} | Column address strobe | V _{TT} | SDRAM I/O termination power supply |
| \overline{WE} | Write Enable | TEST | Memory bus test tool |
| SCL | SPD Clock Input | V _{DD} | Core Power |
| SDA | SPD Data Input/Output | V _{DDQ} | I/O Power |
| SA0~SA2 | SPD Address | V _{SS} | Ground |
| Par_In | Parity bit for address & Control bus | V _{REFDQ} | SDRAM Input/Output Reference Supply |
| Err_Out | Parity error found in the Address and Control bus | V _{DDSPD} | Serial EEPROM Power Supply |
| Reset | Register and PLL control pin | V _{REFCA} | Command Address Reference Supply |

7.0 Address Configuration

| Organization | Row Address | Column Address | Bank Address | Auto Pre-charge |
|--------------------|-------------|----------------|--------------|-----------------|
| 128Mx4(512Mb) base | A0-A13 | A0-A9, A11 | BA0-BA1 | A10 |
| 64Mx8(512Mb) base | A0-A13 | A0-A9 | BA0-BA1 | A10 |
| 128Mx8(1Gb)base | A0-A13 | A0-A9 | BA0-BA2 | A10 |
| 256Mx4(1Gb)base | A0-A13 | A0-A9, A11 | BA0-BA2 | A10 |
| 256Mx8(2Gb)base | A0-A14 | A0-A9 | BA0-BA2 | A10 |
| 512Mx4(2Gb)base | A0-A14 | A0-A9, A11 | BA0-BA2 | A10 |

240-Pin DDR3- Reg/ECC-DIMM

DDR3 SDRAM

8.1 Functional Block Diagram: 1GB / 128Mx7 2 Module (Populated as 1 rank of x8 SDRAM Module)

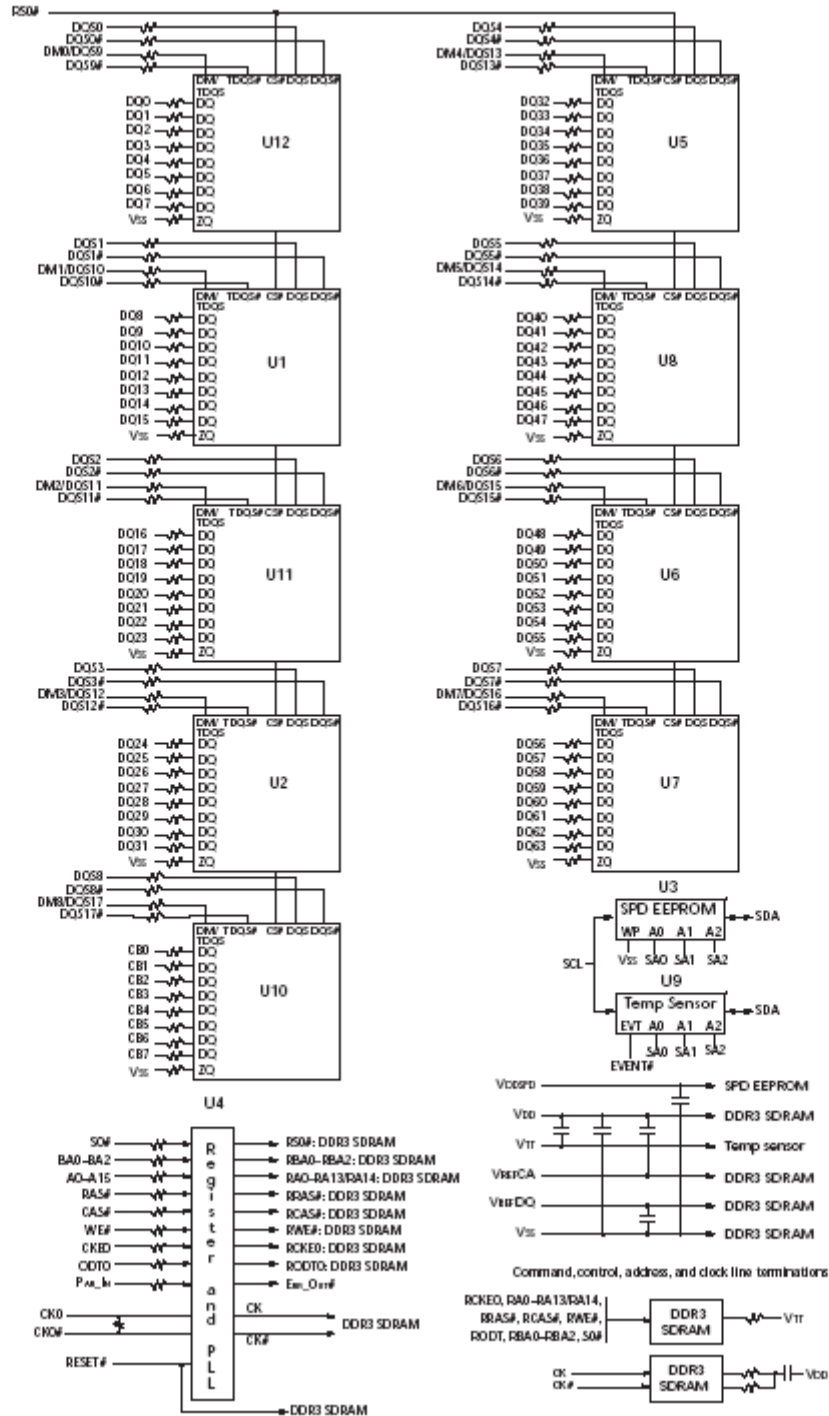

8.2 Functional Block Diagram: 2GB, 256x72 Module (Populated as 2 ranks of x8 SDRAM Module)

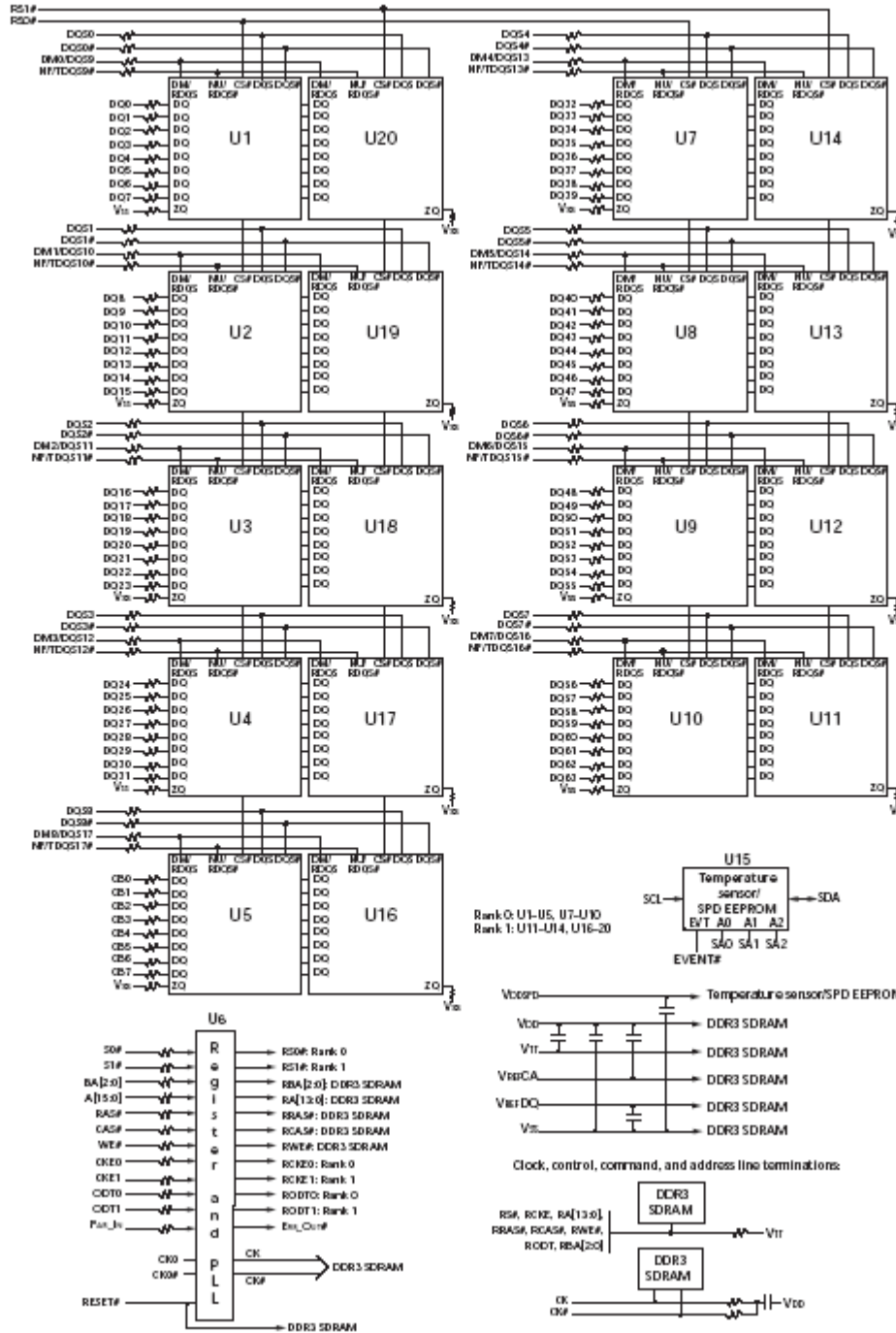

8.3 Functional Block Diagram: 2GB, 256x72 Module (Populated as 1 rank of x4 SDRAM Module)

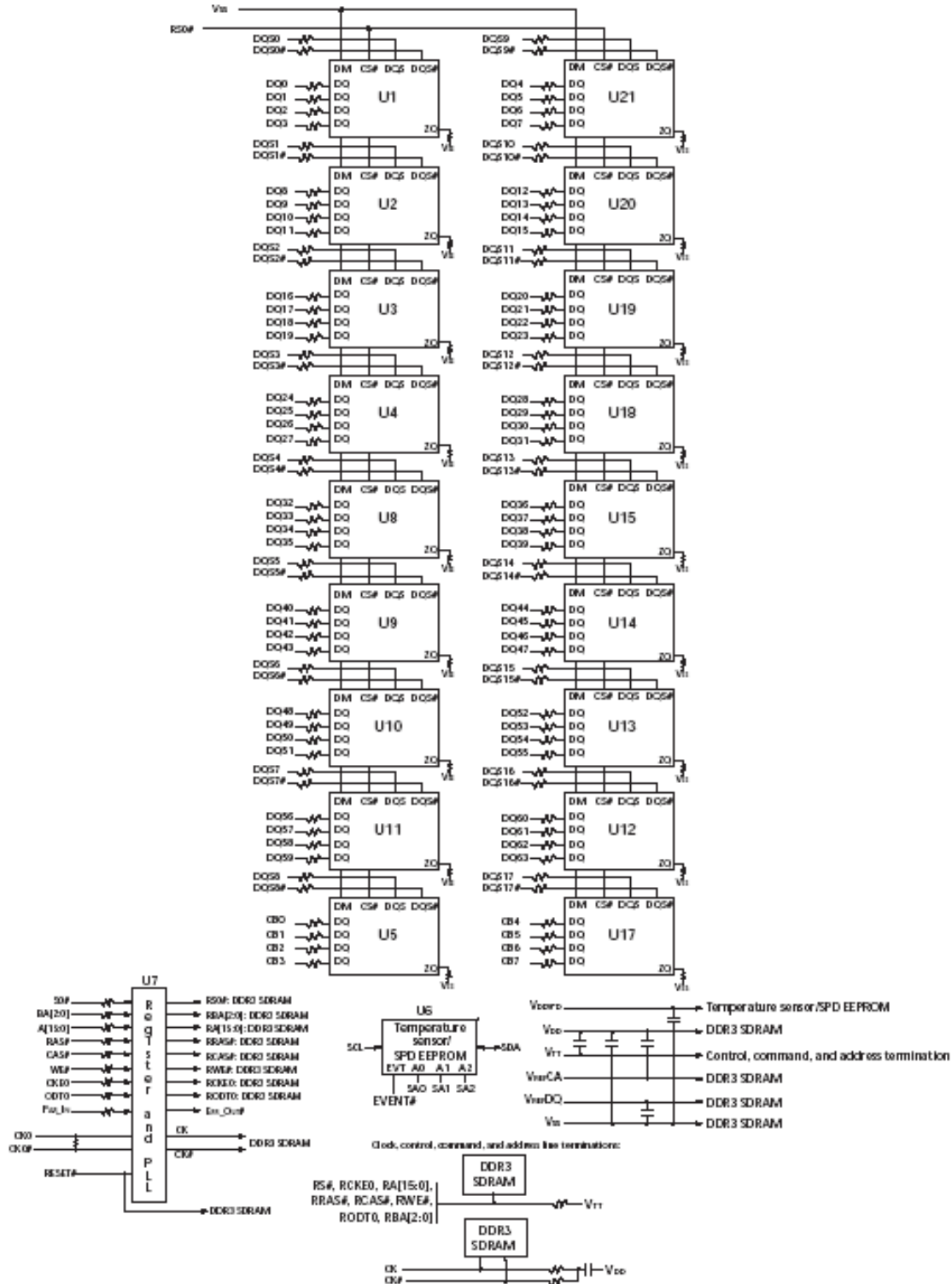

Notes: 1. The ZQ ball on each DDR3 component is connected to an external 240Ω ±1 percent resistor that is tied to ground. It is used for the calibration of the component's ODT and output driver.

240-Pin DDR3- Reg/ECC-DIMM

DDR3 SDRAM

8.4 Functional Block Diagram: 2GB/4GB, 256x72/512x72 Module (Populated as 2 ranks of x4 SDRAM Module)

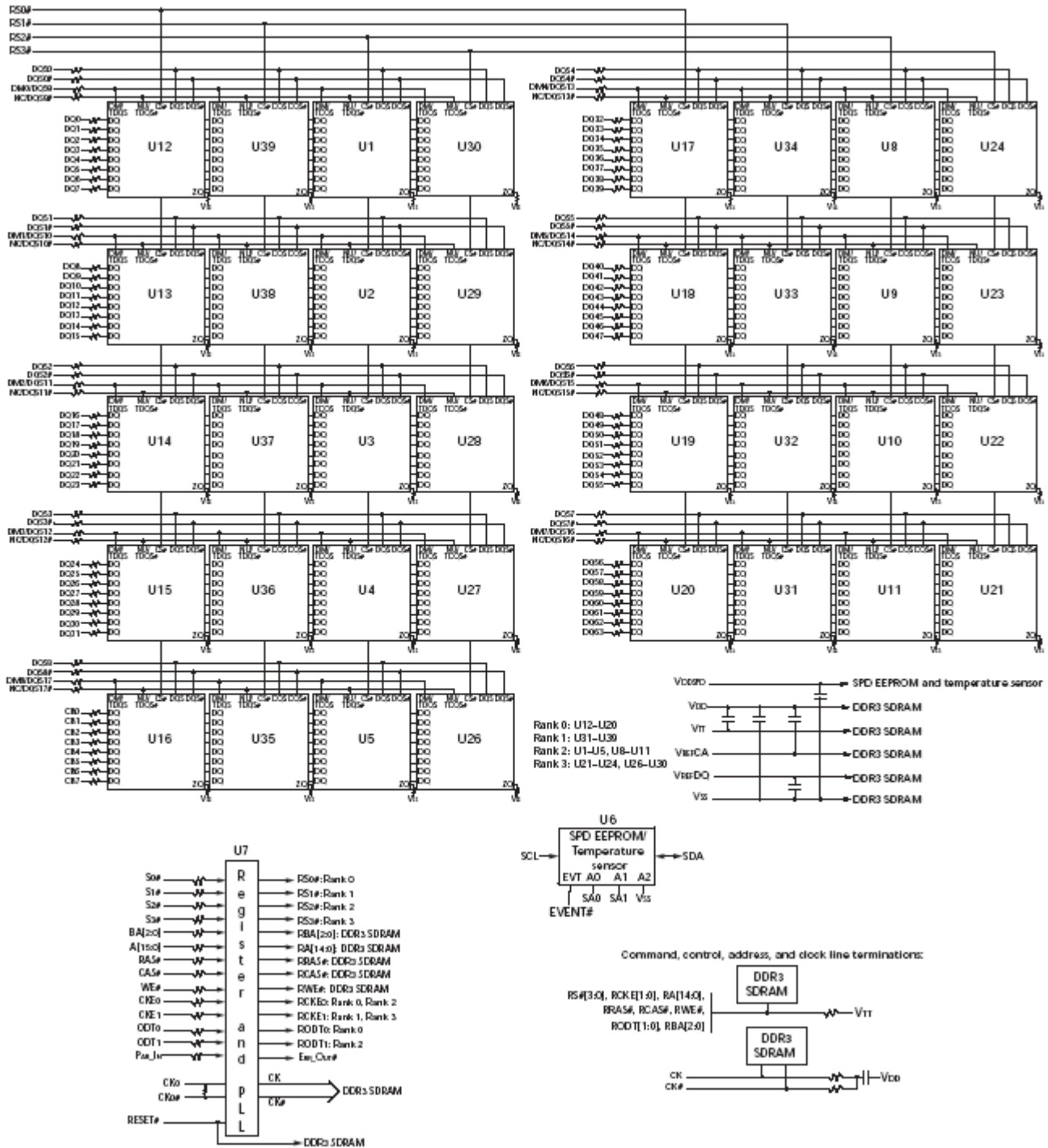

9.0 AC & DC Operating Conditions

Recommended operating conditions (Voltage referenced to V_{SS}=0V, TA=0 to 70°C)

| Symbol | Parameter | Min | Typ | Max | Unit |
|------------------------|---------------------------------|-----------------------|-----------------------|-----------------------|------|
| V _{DD} | Supply Voltage | 1.425 | 1.5 | 1.575 | V |
| V _{DDQ} | Supply Voltage for Output | 1.425 | 1.5 | 1.575 | V |
| V _{REFDQ(DC)} | I/O Reference Voltage (DQ) | 0.49*V _{DDQ} | 0.50*V _{DDQ} | 0.51*V _{DDQ} | V |
| V _{REFCA(DC)} | I/O Reference Voltage (CMD/Add) | 0.49*V _{DDQ} | 0.50*V _{DDQ} | 0.51*V _{DDQ} | V |
| V _{TT} | Termination Voltage | 0.49*V _{DDQ} | 0.50*V _{DDQ} | 0.51*V _{DDQ} | V |

10.0 Capacitance (Max.)

| Symbol | Parameter/Condition | Min | Max | Unit |
|--------|--|-----|-----|------|
| CCK | Input capacitance, CK and \overline{CK} | - | 11 | pF |
| CI1 | Input capacitance, CKE and \overline{CS} | - | 12 | pF |
| CI2 | Input capacitance, Addr, RAS, CAS, \overline{WE} | - | 12 | pF |
| CIO | Input capacitance, DQ, DM, DQS, \overline{DQS} | - | 10 | pF |

11.1 AC Timing Parameters & Specifications

(AC operating conditions unless otherwise noted)

| Parameter | Symbol | DDR3-1066 | | DDR3-1333 | | Units | Notes |
|--|----------------|-----------------------------------|-----------------------------------|-----------------------------------|-----------------------------------|----------|-------|
| | | min | max | min | max | | |
| Minimum Clock Cycle Time (DLL off mode) | tCK(DLL_OFF) | 8 | - | 8 | - | ns | 6 |
| Average Clock Period | tCK(avg) | See Speed Bins Table | | | | ps | |
| Clock Period | tCK(abs) | tCK(avg) min +tJIT (per)min | tCK(avg) max +tJIT (per)max | tCK(avg) min +tJIT (per)min | tCK(avg) max +tJIT (per)max | ps | |
| Average high pulse width | tCH(avg) | 0.47 | 0.53 | 0.47 | 0.53 | tCK(avg) | |
| Average low pulse width | tCL(avg) | 0.47 | 0.53 | 0.47 | 0.53 | tCK(avg) | |
| Clock Period Jitter | tJIT(per) | -90 | 90 | -80 | 80 | ps | |
| Clock Period Jitter during DLL locking period | tJIT(per, lck) | -90 | 90 | -80 | 80 | ps | |
| Cycle to Cycle Period Jitter | tJIT(cc) | 180 | | 160 | | ps | |
| Cycle to Cycle Period Jitter during DLL locking period | tJIT(cc, lck) | 160 | | 140 | | ps | |
| Cumulative error across 2 cycles | tERR(2per) | - 132 | 132 | - 118 | 118 | ps | |
| Cumulative error across 3 cycles | tERR(3per) | - 157 | 157 | - 140 | 140 | ps | |
| Cumulative error across 4 cycles | tERR(4per) | - 175 | 175 | - 155 | 155 | ps | |
| Cumulative error across 5 cycles | tERR(5per) | - 188 | -188 | - 168 | 168 | ps | |
| Cumulative error across 6 cycles | tERR(6per) | - 200 | 200 | - 177 | 177 | ps | |
| Cumulative error across 7 cycles | tERR(7per) | - 209 | 209 | - 186 | 186 | ps | |
| Cumulative error across 8 cycles | tERR(8per) | - 217 | 217 | - 193 | 193 | ps | |
| Cumulative error across 9 cycles | tERR(9per) | - 224 | 224 | - 200 | 200 | ps | |
| Cumulative error across 10 cycles | tERR(10per) | - 231 | 231 | - 205 | 205 | ps | |

11.2 AC Timing Parameters & Specifications (con't)

| Parameter | Symbol | DDR3-1066 | | DDR3-1333 | | Units | Notes |
|---|-------------|--|---------|---------------------|---------|----------|----------|
| | | min | max | min | max | | |
| Cumulative error across 11 cycles | tERR(11per) | - 237 | 237 | - 210 | 210 | ps | |
| Cumulative error across 12 cycles | tERR(12per) | - 242 | 242 | - 215 | 215 | ps | |
| Cumulative error across n = 13, 14 ... 49, 50 cycles | tERR(nper) | $tERR(nper)_{min} = (1 + 0.68\ln(n)) * tJIT(per)_{min}$ $tERR(nper)_{max} = (1 + 0.68\ln(n)) * tJIT(per)_{max}$ | | | | ps | 24 |
| Absolute clock HIGH pulse width | tCH(abs) | 0.43 | - | 0.43 | - | tCK(avg) | 25 |
| Absolute clock Low pulse width | tCL(abs) | 0.43 | - | 0.43 | - | tCK(avg) | 26 |
| Data Timing | | | | | | | |
| DQS, /DQS to DQ skew, per group, per access | tDQSQ | - | 150 | - | 125 | ps | 13 |
| DQ output hold time from DQS, /DQS | tQH | 0.38 | - | 0.38 | - | tCK(avg) | 13,g |
| DQ low-impedance time from CK, /CK | tLZ(DQ) | -600 | 300 | -500 | 250 | ps | 13,14,f |
| DQ high-impedance time from CK, /CK | tHZ(DQ) | - | 300 | - | 250 | ps | 13,14,f |
| Data setup time to DQS, /DQS referenced to Vih(ac)/Vil(ac) levels | tDS(base) | 25 | - | TBD | - | ps | d,17 |
| Data hold time to DQS, /DQS referenced to Vih(ac)/Vil(ac) levels | tDH(base) | 100 | - | TBD | - | ps | d,17 |
| DQ and DM Input pulse width for each input | tDIPW | 490 | - | 400 | - | ps | 28 |
| Data Strobe Timing | | | | | | | |
| DQS, /DQS READ Preamble | tRPRE | 0.9 | Note 19 | 0.9 | Note 19 | tCK | 13,19,g |
| DQS, /DQS differential READ Postamble | tRPST | 0.3 | Note 11 | 0.3 | Note 11 | tCK | 11,13,g |
| DQS, /DQS output high time | tQSH | 0.38 | - | 0.4 | - | tCK(avg) | |
| DQS, /DQS output low time | tQSL | 0.38 | - | 0.4 | - | tCK(avg) | |
| DQS, /DQS WRITE Preamble | tWPRE | 0.9 | - | 0.9 | - | tCK | |
| DQS, /DQS WRITE Postamble | tWPST | 0.3 | - | 0.3 | - | tCK | |
| DQS, /DQS rising edge output access time from rising CK, /CK | tDQSCK | -300 | 300 | -255 | 255 | ps | 13,f |
| DQS, /DQS low-impedance time (Referenced from RL-1) | tLZ(DQS) | -600 | 300 | -500 | 250 | ps | 13,14,f |
| DQS, /DQS high-impedance time (Referenced from RL+BL/2) | tHZ(DQS) | 300 | - | 250 | - | ps | 12,13,14 |
| DQS, DQS differential input low pulse width | tDQSL | 0.45 | 0.55 | 0.45 | 0.55 | tCK | 28,30 |
| DQS, DQS differential input high pulse width | tDQSH | 0.45 | 0.55 | 0.45 | 0.55 | tCK | 29,30 |
| DQS, DQS rising edge to CK, CK rising edge | tDQSS | -0.25 | 0.25 | -0.25 | 0.25 | tCK(avg) | C |
| DQS, DQS falling edge setup time to CK, CK rising edge | tDSS | 0.2 | - | 0.2 | - | tCK(avg) | C,31 |
| DQS, DQS falling edge hold time to CK, CK rising edge | tDSH | 0.2 | - | 0.2 | - | tCK(avg) | C,31 |
| DLL locking time | tDLLK | 512 | - | 512 | - | nCK | |
| internal READ Command to PRECHARGE Command delay | tRTP | max (4tCK,7.5ns) | - | max (4tCK,7.5ns) | - | | e |
| Delay from start of internal write transaction to internal read command | tWTR | max (4tCK,7.5ns) | - | max (4tCK,7.5ns) | - | | e,18 |
| WRITE recovery time | tWR | 15 | - | 15 | - | ns | e |
| Mode Register Set command cycle time | tMRD | 4 | - | 4 | - | nCK | |
| Mode Register Set command update delay | tMOD | max (12tCK,15ns) | - | max (12tCK,15ns) | - | | |
| CAS# to CAS# command delay | tCCD | 4 | - | 4 | - | nCK | |
| Auto precharge write recovery + precharge time | tDAL(min) | WR + roundup (tRP / tCK(AVG)) | | | | nCK | |

11.3 AC Timing Parameters & Specifications (con't)

| Parameter | Symbol | DDR3-1066 | | DDR3-1333 | | Units | Notes |
|--|--------------------|-------------------------------|---------|-------------------------------|---------|-------|---------|
| | | min | max | min | max | | |
| Multi-Purpose Register Recovery Time | tMPRR | 1 | - | 1 | - | nCK | |
| ACTIVE to PRECHARGE command period | tRAS | 37.5 | 70,000 | 36 | 70,000 | ns | e |
| ACTIVE to ACTIVE command period for 1KB page size | tRRD | max (4tCK,7.5ns) | - | max (4tCK,6ns) | - | | e |
| ACTIVE to ACTIVE command period for 2KB page size | tRRD | max (4tCK,10ns) | - | max (4tCK,7.5ns) | - | | e |
| Four activate window for 1KB page size | tFAW | 37.5 | - | 30 | - | ns | e |
| Four activate window for 2KB page size | tFAW | 50 | - | 45 | - | ns | e |
| Command and Address setup time to CK, CK referenced to Vih(ac) / Vil(ac) levels | tIS(base) | 125 | - | 65 | - | ps | b,16 |
| Command and Address hold time from CK, CK referenced to Vih(ac) / Vil(ac) levels | tIH(base) | 200 | - | 140 | - | ps | b,16 |
| Command and Address setup time to CK, CK referenced to Vih(ac) / Vil(ac) levels | tIS(base) AC150 | - | - | 65+125 | - | ps | b,16,27 |
| Control & Address Input pulse width for each input | tIPW | 780 | - | 620 | - | ps | 28 |
| Calibration Timing | | | | | | | |
| Power-up and RESET calibration time | tZQinitl | 512 | - | 512 | - | tCK | |
| Normal operation Full calibration time | tZQoper | 25 | - | 256 | - | tCK | |
| Normal operation short calibration time | tZQCS | 64 | - | 64 | - | tCK | 23 |
| Reset Timing | | | | | | | |
| Exit Reset from CKE HIGH to a valid command | tXPR | max(5tCK, tRFC+ 10ns) | - | max(5tCK, tRFC+ 10ns) | - | | |
| Self Refresh Timing | | | | | | | |
| Exit Self Refresh to commands not requiring a locked DLL | tXS | max(5tCK,tRF C+ 10ns) | - | max(5tCK,tRF C+ 10ns) | - | | |
| Exit Self Refresh to commands requiring a locked DLL | tXSDLL | tDLLK(min) | - | tDLLK(min) | - | nCK | |
| Minimum CKE low width for Self refresh entry to exit timing | tCKESR | tCKE(min) + 1tCK | - | tCKE(min) + 1tCK | - | | |
| Valid Clock Requirement after Self Refresh Entry (SRE) | tCKSRE | max(5tCK, 10ns) | - | max(5tCK, 10ns) | - | | |
| Valid Clock Requirement before Self Refresh Exit (SRX) | tCKSRX | max(5tCK, 10ns) | - | max(5tCK, 10ns) | - | | |
| Power Down Timing | | | | | | | |
| Exit Power Down with DLL on to any valid command; Exit Precharge Power Down with DLL frozen to commands not requiring a locked DLL | tXP | max (3tCK,7.5ns) | - | max (3tCK,6ns) | - | | |
| Exit Precharge Power Down with DLL frozen to commands requiring a locked DLL | tXPDLL | max(10tCK, 24ns) | - | max(10tCK, 24ns) | - | | 2 |
| CKE minimum pulse width | tCKE | max(3tCK, 5.625ns) | - | max(3tCK, 5.625ns) | - | | |
| Command pass disable delay | tCPDED | 1 | - | 1 | - | nCK | |
| Power Down Entry to Exit Timing | tPD | tCKE(min) | 9*tREFI | tCKE(min) | 9*tREFI | tCK | 15 |
| Timing of ACT command to Power Down entry | tACTPDEN | 1 | - | 1 | - | nCK | 20 |
| Timing of PRE command to Power Down entry | tPRPDEN | 1 | - | 1 | - | nCK | 20 |
| Timing of RD/RDA command to Power Down entry | tRDPDEN | RL + 4 + 1 | - | RL + 4 + 1 | - | | |
| Timing of WR command to Power Down entry (BL8OTF, BL8MRS, BL4OTF) | tWRPDEN | WL + 4 +(tWR/tCK) | - | WL + 4 +(tWR/tCK) | - | nCK | 9 |
| Timing of WRA command to Power Down entry (BL8OTF, BL8MRS, BL4OTF) | tWRAPDEN | WL + 4 +WR+1 | - | WL + 4 +WR+1 | - | nCK | 10 |
| Timing of WR command to Power Down entry (BL4MRS) | tWRPDEN | WL + 2 +(tWR/ tCK(avg)) | - | WL + 2 +(tWR/ tCK(avg)) | - | nCK | 9 |

11.4 AC Timing Parameters & Specifications (con't)

| Parameter | Symbol | DDR3-1066 | | DDR3-1333 | | Units | Notes |
|--|----------|-----------------|-----|-----------------|-----|----------|-------|
| | | min | max | min | max | | |
| Timing of WRA command to Power Down entry (BL4MRS) | tWRAPDEN | WL +2 +WR +1 | - | WL +2 +WR +1 | - | nCK | 10 |
| Timing of REF command to Power Down entry | tREFPDEN | 1 | - | 1 | - | | 20,21 |
| Timing of MRS command to Power Down entry | tMRSPDEN | tMOD(min) | - | tMOD(min) | - | | |
| ODT Timing | | | | | | | |
| ODT high time without write command or with write command and BC4 | ODTH4 | 4 | - | 4 | - | nCK | |
| ODT high time with Write command and BL8 | ODTH8 | 6 | - | 6 | - | nCK | |
| Asynchronous RTT turn-on delay (Power-Down with DLL frozen) | tAONPD | 1 | 9 | 1 | 9 | ns | |
| Asynchronous RTT turn-off delay (Power-Down with DLL frozen) | tAOFPD | 1 | 9 | 1 | 9 | ns | |
| ODT turn-on | tAON | -300 | 300 | -250 | 250 | ps | 7,f |
| RTT_NOM and RTT_WR turn-off time from ODTL off reference | tAOF | 0.3 | 0.7 | 0.3 | 0.7 | tCK(avg) | 8,f |
| RTT dynamic change skew | tADC | 0.3 | 0.7 | 0.3 | 0.7 | tCK(avg) | f |
| Write Leveling Timing | | | | | | | |
| First DQS pulse rising edge after tDQSS margining mode is programmed | tWLMRD | 40 | - | 40 | - | tCK | 3 |
| DQS/DQS delay after tDQS margining mode is programmed | tWLDQSEN | 25 | - | 25 | - | tCK | 3 |
| Setup time for tDQSS latch | tWLS | 245 | - | 195 | - | ps | |
| Hold time of tDQSS latch | tWLH | 245 | - | 195 | - | ps | |
| Write leveling output delay | tWLO | 0 | 9 | 0 | 9 | ns | |
| Write leveling output error | tWLOE | 0 | 2 | 0 | 2 | ns | |

240-Pin DDR3- Reg/ECC-DIMM

DDR3 SDRAM

12.1 Physical Dimensions: (128Mx8 Based) 128Mx72 (1 Rank)

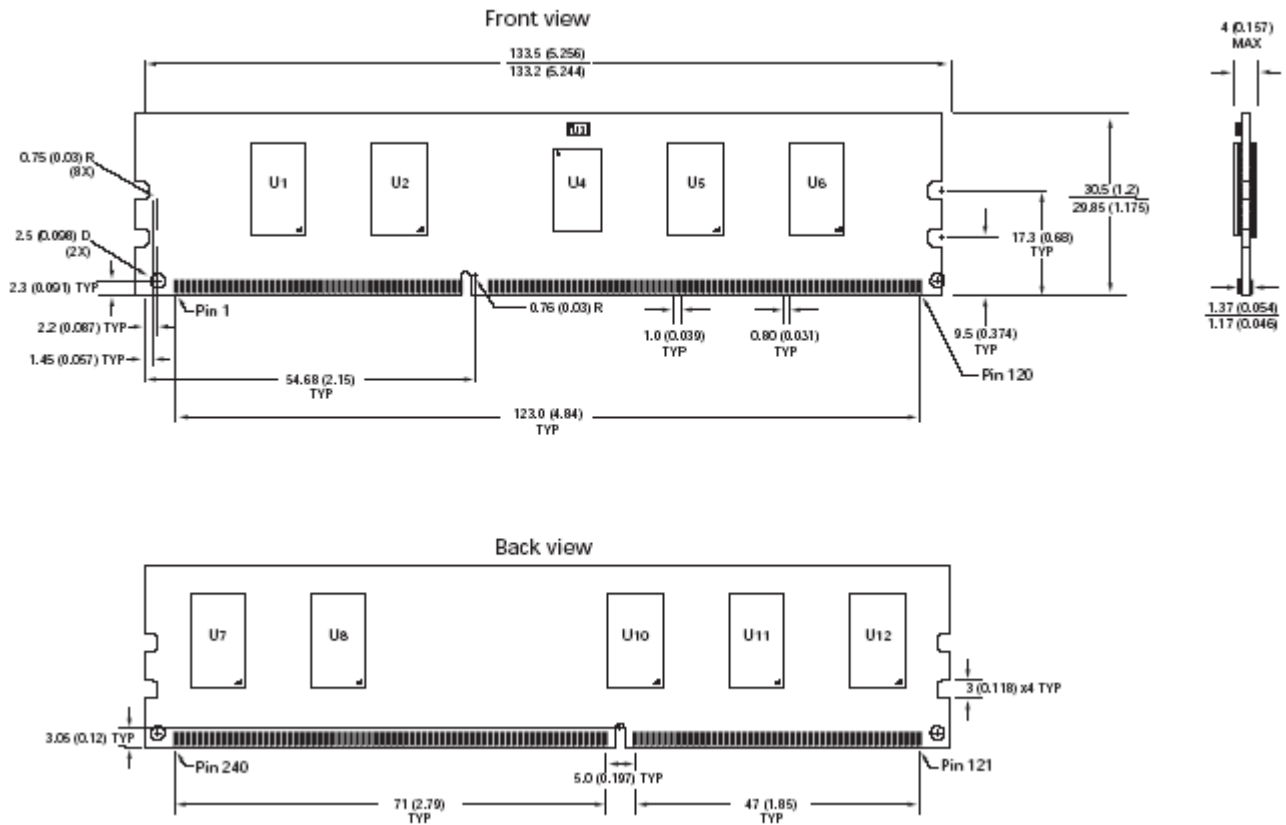

Tolerances: $\pm 0.005(.13)$ unless otherwise specified

240-Pin DDR3- Reg/ECC-DIMM

DDR3 SDRAM

12.2 Physical Dimensions: (128Mx8 / 256Mbx4 Based) 256Mx72 (2 Ranks)

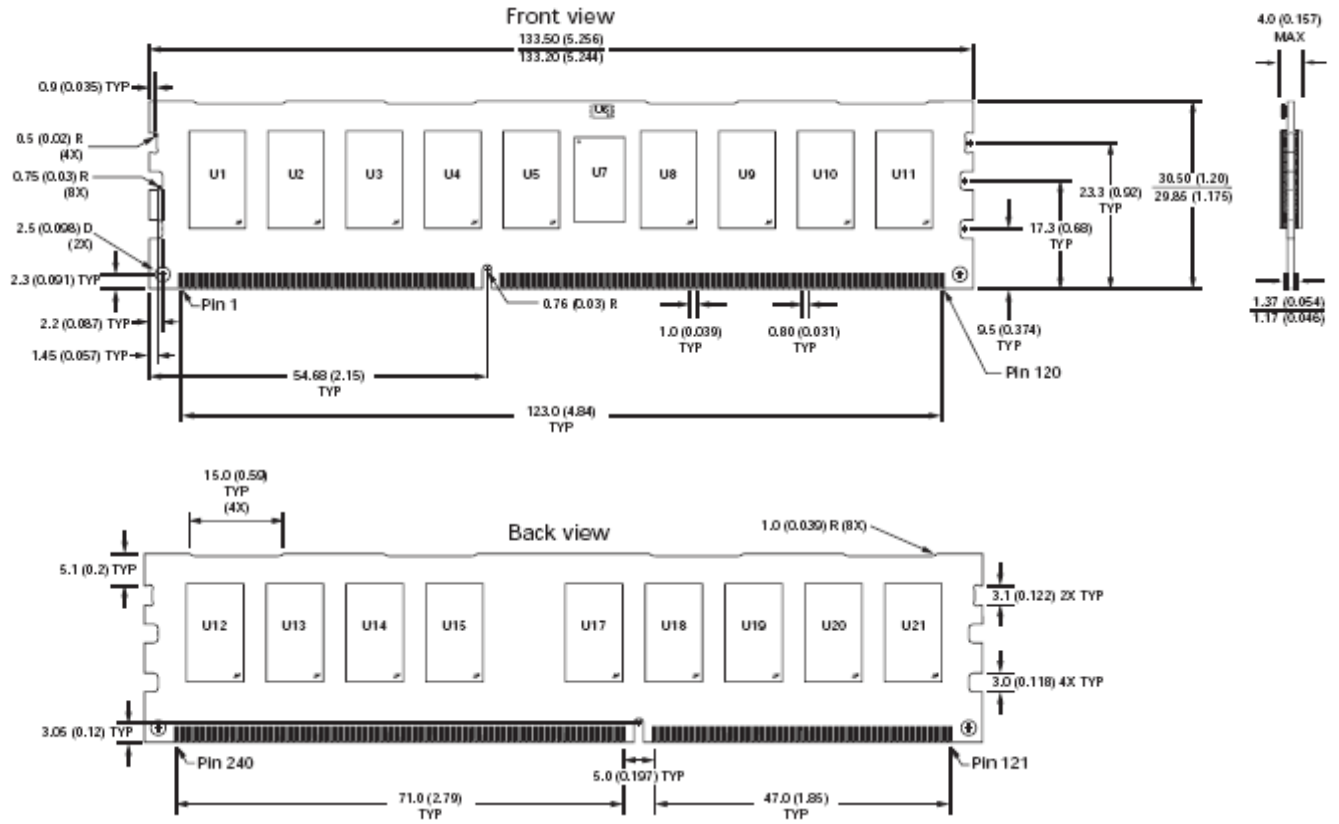

Tolerances: $\pm 0.005(.13)$ unless otherwise specified

240-Pin DDR3- Reg/ECC-DIMM

DDR3 SDRAM

**12.3 Physical Dimensions: (256Mx4 Based)
512Mx72 (2 Ranks)**

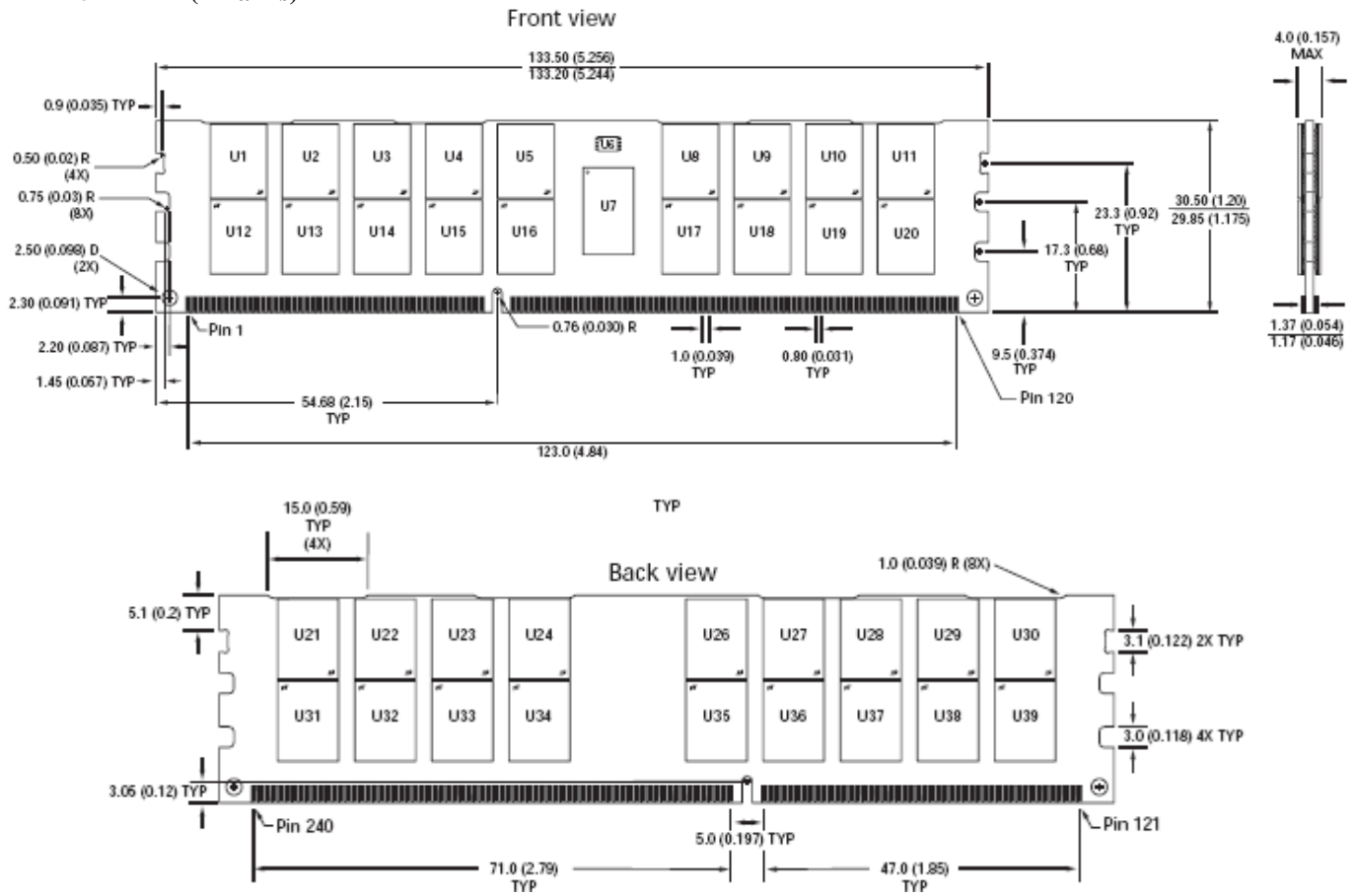

Tolerances: ± 0.005(.13) unless otherwise specified